



**SUPERLIFT**  
POWER LIFTS

TRUCKS

# Hercules Pallet Truck

## 10,000 lbs Capacity

Introducing the Unrivaled Powerhouse: **Hercules 10,000 lb Heavy-Duty Pallet Truck**. Are you tired of struggling with heavy loads and inefficient material handling equipment? Look no further! We proudly present the **10,000 lb Heavy-Duty Pallet Truck**, your ultimate solution for effortless and efficient transportation of heavy loads.

**UNLEASH THE POWER:** Featuring an extraordinary lifting capacity of 10,000 lbs, this heavy-duty pallet truck is a true powerhouse. It's specifically engineered to handle the toughest material handling challenges in warehouses, factories, distribution centers, and more. Say goodbye to back-breaking labor and hello to productivity!

**UNMATCHED DURABILITY:** Crafted with durability in mind, our heavy-duty pallet truck is built to withstand the harshest working conditions. Constructed from high-quality materials, this robust machine is designed to last for years, ensuring a solid return on your investment. It's time to upgrade to a reliable workhorse that never lets you down.

**PRECISION AND CONTROL:** Equipped with advanced control features, our pallet truck ensures smooth and precise movements, even with the heaviest loads. The ergonomic design and intuitive controls provide maximum comfort and ease of use for your operators. Boost their productivity while minimizing fatigue and strain.

**EFFICIENCY AT ITS FINEST:** Every minute counts in a fast-paced work environment. The 10,000 lb Heavy-Duty Pallet Truck is designed to optimize efficiency and streamline your operations. Its superior maneuverability allows for seamless navigation in tight spaces, while the powerful motor ensures swift and accurate load handling.

**SAFETY FIRST:** We prioritize the well-being of your workforce. Our heavy-duty pallet truck comes equipped with cutting-edge safety features, including robust brakes, anti-slip traction, and intelligent stability control. Rest assured that your team can handle heavy loads with confidence and minimize the risk of accidents.



**EASY MAINTENANCE:** We understand that downtime is costly. That's why we've engineered our pallet truck for quick and hassle-free maintenance. Routine servicing is a breeze, thanks to the accessible components and user-friendly design. Keep your operations running smoothly and avoid unnecessary delays.

**THE PERFECT FIT FOR YOUR NEEDS:** We offer a range of customization options to tailor the 10,000 lb Heavy-Duty Pallet Truck to your specific requirements. From additional safety features to specialized attachments, our experts will work closely with you to create the ideal solution that meets your unique needs.

**INVEST IN EXCELLENCE:** When it comes to heavy-duty material handling, settle for nothing less than the best. The 10,000 lb Heavy-Duty Pallet Truck combines exceptional lifting capacity, durability, precision, efficiency, and safety into one remarkable machine. Experience the difference and revolutionize your material handling operations today. Contact us now to learn more about the 10,000 lb Heavy-Duty Pallet Truck and discover how it can transform your business. **Don't wait another moment to upgrade to the ultimate powerhouse in the world of material handling!**



**SUPERLIFT**  
POWER LIFTS

TRUCKS

# Hercules Pallet Truck

## 10,000 lbs Capacity

### Features

- 10,000lbs capacity at 24" load center
- All steel chassis heavy duty weld built to ANSI B56.1 with all the parts laser cut for precision fit
- Lowered height 3.5"
- Raised height 9"
- Fork 27" od x 48" long x 9" wide x 2.75" thick
- $\phi 3.25$ " load wheels
- Single heavy duty drive DC motor with two support casters
- Electric brakes
- Mosfet controller 24 v DC UL
- Powered assisted steering tiller style.
- Battery indicator key switch in handle
- Single non marking poly tire x 5" dual drive with heavy duty. Two side support casters
- Battery compartment 34.4" long x 25.4" height x 9" width compartment
- Bdi/hour meter included and key switch
- Controls in the handle for forward and reverse and up and down
- Finish painted

### Drawings

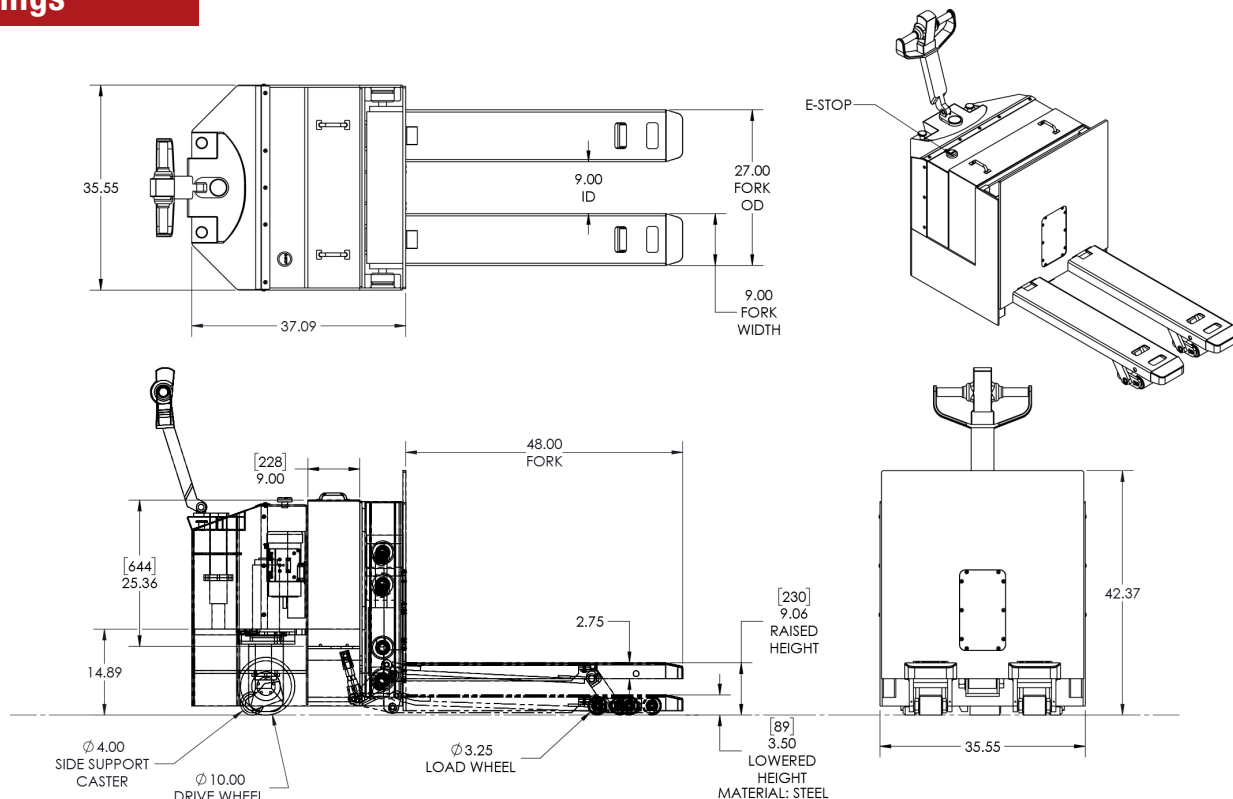

**:: Custom sizes available ::**